

Aarudi Ranganth Shashikala^{1*}, Kothakula Keerthi¹,
Sridhar Bangarpet Shankar²

^{1,2}Department of Chemistry, Presidency University, Itgalpura,
Bengaluru-64, India,²Department of Industrial Engineering and
Management, MSRIT, Bengaluru-54, India.

Scientific paper

ISSN 0351-9465, E-ISSN 2466-2585

<https://doi.org/10.62638/ZasMat1135>



Zastita Materijala 65 (2)
236 - 245 (2024)

Electrochemical investigations of Ni-P/nano c-BN deposited on aluminum alloy

ABSTRACT

Electrochemical investigations were carried out on the Ni-P/nano cubic-Boron Nitride (c-BN) coatings obtained by using sodium hypophosphite reduced electrolyte bath solution with complexing agents. The screening of complexing agents was carried out by UV-Visible spectrophotometric studies. The deposits obtained using optimized bath composition was tested by EDAX, SEM and XRD in order to understand the structural morphology of the coatings. Electrochemical studies conducted by Potentiodynamic polarization and Electrochemical Impedance Spectroscopy (EIS) revealed the greater stability of coatings in acidic and alkaline environment. To evaluate the behavior of the coatings in marine environment, Salt spray test was conducted using sodium chloride solution. Results indicate the improved resistance to corrosion with the incorporation of nano c-BN in the coatings.

Keywords: cubic-Boron Nitride, Corrosion resistance, Polarization, EIS, Salt spray

1. INTRODUCTION

Over the years, electroless nickel phosphorous (Ni-P) coatings is used extensively for industrial applications as it provides protection against corrosion, has enhanced mechanical properties and the coatings have superior uniformity with improved life span to the work pieces [1-4]. Electroless nickel deposits can be obtained uniformly on complex shaped objects. The mechanical and chemical properties of Ni-P plating depends on phosphorus content, degree of crystallinity, crystal size and plating bath conditions [5-7]. After annealing, hardness of the binary Ni-P coatings decreased due to increase in crystal structure [8]. Ternary Ni-P-Cu, Ni-Zn-P, Ni-W-P, Ni-Cr-P and Ni-Mo-P have been studied by many authors [9-16]. These ternary coatings enhance the durability of alloy coatings at elevated temperatures. Incorporation of multiple metals in the coatings found to improve the thermal and mechanical properties at higher temperature. However, controlling the phosphorous content and composition of third element in coating will be a challenge [17].

It is difficult to reduce few metals while obtaining ternary electro less deposits. When a metal is difficult to get reduced, its share in the composite cannot reach appreciable values [18]. Ni-Cr-P coatings containing 4% chromium has been studied by Tadashi [19]. Ni-Cr-P deposition by ion exchange method was carried out by researchers [20]. A review related to the deposition of ternary alloys was published [21]. Among the ternary alloys developed only Ni-P coatings with Fe, Co and Cu found to have more practical applications, as they provide uniform thickness deposits on complex, irregular objects with critical dimensions. They also provide coatings with higher hardness, wear resistance and corrosion resistance.

It is reported in literature that addition of nano particles in the binary plating bath enhances the mechanical properties of the composite coating [22-28]. Over the years, Ni-P composite coatings with nano ZnO, TiO₂, Ti, WC, h-BN, SiO₂, SiC and Al₂O₃ have been studied by several researchers [29-32]. Dense, uniform, crack free coatings with higher protection against corrosion were obtained by the incorporation of nano particles. Hexagonal BN (h-BN) offers high corrosion resistance, thermal stability and can function as excellent lubricant [33]. However, h-BN has poor wettability and friction control properties below 400°C [34-35]. Nano c-BN, being extremely hard, improves the micro hardness of the composite coating and corrosion resistance. Dispersion and dissolution of these nano powders

*Corresponding author: A. R. Shashikala¹

Email: aarudirs@gmail.com

Paper received: 25. 09. 2023.

Paper corrected: 29.11.2023.

Paper accepted: 07. 12. 2023.

Paper is available on the website: www.idk.org.rs/journal

in the electrolyte bath solution is a challenge. Continuous agitation through ultra-sonication is required to disperse the same in the bath solution effectively [36].

Acidic hypophosphite plating baths have a number of advantages over the alkaline ammonical baths due to its higher plating rates, good stability and produce deposits with improved properties. Many formulations for acidic hypophosphite based electroless nickel baths have been reported in literature [37-41].

Owing to excellent properties of nano c-BN, in the present study nano c-BN reinforced electroless Ni-P composite coatings (Ni-P/nano c-BN) were produced in a hypophosphite reduced bath solution on 6061- Al substrate in acidic medium. The influence of nano c-BN on the tribological and anticorrosion behaviour of the coatings were studied.

2. EXPERIMENTAL PROCEDURE

2.1. Electroless Ni-P/nano c-BN coatings

Analytical grade reagents were used for the development of Ni-P/nano c-BN on aluminum alloy substrates. The deposition was carried out as per the below mentioned steps [42]. Ball milled nano c-BN with particle size 63-70nm was used for the development of composite coating.

1. Solvent degreasing: Substrate surface was degreased using an organic solvent by ultra-sonication at 25°C.
2. Alkaline cleaning: Alkali cleaning was carried out by dipping the specimens in an alkaline solution at 55 to 60°C for five minutes.
3. De-smutting: Acid scales and other impurities were removed by dipping the substrate in a solution containing mixture of acids for 50 seconds at 25°C.
4. Alloy zincating was carried out at 25°C, followed by electroless plating [43].
5. Electroless Ni-P/nano c-BN plating was obtained on pre-cleaned 6061 –Al substrates in an electrolytic bath solution containing NiSO₄·7H₂O, NaH₂PO₂, Na₃C₄H₆O₄·6H₂O, NH₂-CH₂-COOH, NH₄SO₄, PbNO₃, CHNaSO and nano c-BN, at pH 4.5 and temperature 90±2 °C as indicated in Table 1.

NiSO₄·7H₂O and nano c-BN was used as source of nickle and nano particle respectively, NaH₂PO₂ acts as reducing agent, Na₃C₄H₆O₄·6H₂O and NH₂-CH₂-COOH are the complexing agents, NH₄SO₄ is used as conducting salt, PbNO₃ provides lead ions in the solution facilitating bright coating, sodium lauryl sulphate acts as wetting agent.

2.2. Measurement techniques

2.2.1. Characterization techniques

Double beam UV-Visible spectrophotometer 2202, Sytronics, was used for screening the complexing agents. To examine the morphology and composition of the coatings Scanning electron microscope (Noran scientific analyzer, USA) was used. X-ray diffraction patterns of the coatings were obtained by X-ray diffractometer with CuK α radiation.

2.2.2. Corrosion studies

Protection efficiency of the coatings in acidic and alkaline medium was evaluated by the following techniques:

- a. Polarization studies: Potentiodynamic polarisation studies were conducted in 0.5 N NaOH and 0.5 N HCl solutions by using electrochemical work station. Electroless Ni-P and Ni-P/nano c-BN coated specimens were used as working electrodes. The specimens were immersed in the aqueous media for 45 minutes of equilibrate time before recording the data. All the experiments were conducted at room temperature. Repeated experiments were carried out to get accurate results.
- b. Electrochemical impedance studies: Impedance measurements were conducted by AC signal with amplitude of 0.01 V at open-circuit potential in the frequency range from 10⁻⁵ to 1 Hz. Before performing experiments, a stabilization time of 45 minutes was provided to achieve a stable open-circuit potential. The cell impedance was measured at the frequency from 1 Hz to 10⁵ Hz.
- c. Salt spray test: The stability of the coatings in acidified Sodium chloride solution was evaluated by neutral salt spray test according to ASTM-B117 standard. Every two hours of salt spray, the samples were removed and observed for any degradation.

All the experiments were carried out on multiple samples prepared under optimum conditions and the results obtained is provided in the experimental section.

3. RESULTS AND DISCUSSION

3.1. Optimization of the plating bath

Complexing agents play very important role in producing good quality deposit [15]. Different complexing agents were screened for Ni²⁺ ions in an electrolytic acidic solution at pH 3.0. Tri sodium citrate and glycine were found to form weak complexes with Ni²⁺ ions in presence of nano c-BN which is one of the main requirements to get even

and non-porous deposit. Figure 1, provides the UV-visible absorption spectrum of complexing agents. The absorption spectrum of the Ni^{2+} ions with glycine and c-BN gives two bands characteristic of metal-ligand complexes of octahedral geometry. The absorption spectrum of Ni^{2+} ions with tri sodium citrate and c-BN also gives two bands characteristic of metal-ligand complexes of octahedral geometry. Whereas the absorption spectrum obtained with both the complexing agents and nano c-BN, has three bands characteristic of metal-ligand complexes of octahedral geometry. As glycine and tri sodium citrate complexing agents form weak bonds with the metal ions, both were used as complexing agents in the plating bath solution.

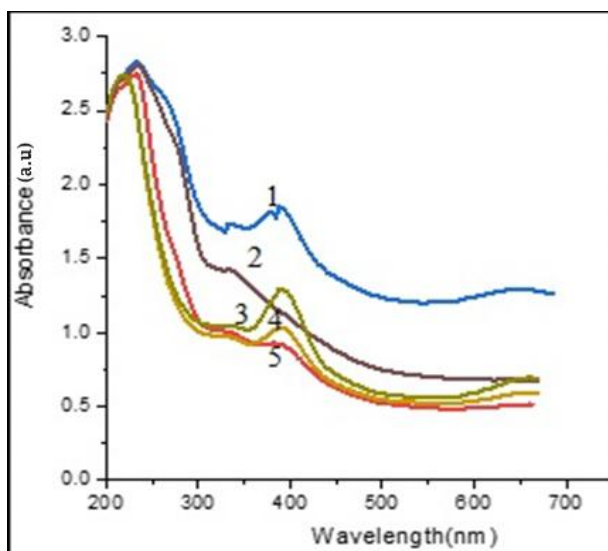

Figure 1. UV absorption spectra 1: Ni^{2+} +TSC+Gly+ c-BN, 2) Nano c-BN, 3) Ni^{2+} +c-BN, 4) Ni^{2+} +Gly+ c-BN, 5) Ni^{2+} +TSC+ c-BN

Slika 1. UV spektri apsorpcije 1: Ni^{2+} +TSC+Gly+ c-BN, 2) Nano c-BN, 3) Ni^{2+} +c-BN, 4) Ni^{2+} +Gly+ c-BN, 5) Ni^{2+} +TSC+ c-BN

Composition of different constituents in the plating bath was varied to optimize the bath composition along with pH and temperature. Concentration of one of the constituent was varied at a time keeping the other constituent's concentration constant. Nickel sulphate concentration was varied from 10 g/L to 40 g/L, sodium hypophosphite and tri sodium citrate concentration was varied from 5 g/L to 35 g/L individually, sodium sulphate concentration was varied from 5 g/L to 20 g/L and nano c-BN concentration was varied from 0.5 g/L to 3 g/L. Nano c-BN with particle size ~66 nm was dispersed in the plating bath solution and subjected to 6 hours of ultra-sonication as solubility of nano particles is low in aqueous solutions. After 6 hours, the solution was filtered and the filtrate was used

for electroless plating on 6061-Al substrates. The concentration of the lead nitrate and sodium lauryl sulphate was kept constant.

The pH of the bath solution was varied from 3.5 to 7.0. Temperature of the plating bath was varied from 70 to 95 °C. At lower pH values the coating obtained was rough and consisted of surface roughness and irregularities. When the pH was increased above 5.5, precipitation of metal oxides and hydroxides was observed. Similarly, the coatings obtained at lower temperatures <90° C was uneven when observed under 4X magnification lens. At higher temperatures, decomposition of bath constituents was observed.

Based on the repeated trials and visual observation of the coatings under 4X magnification lens, the plating bath composition was optimised and the same is tabulated in Table 1. The coatings obtained under optimised conditions were used for the characterization and corrosion studies.

Table 1. Optimised plating bath

Tabela 1. Optimizovana kupka za oplatu

Composition of the plating bath (g/L)	Optimum conditions
NiSO ₄ . 6H ₂ O: 30 NaH ₂ PO ₂ : 20-25 Nano c-BN: 2 Na ₃ C ₆ H ₅ O ₇ : 25 Glycine: 5 NH ₄ SO ₄ : 10-15 Lead Nitrate: 0.001 Sodium Lauryl Sulphate: 0.01	Temp: 90 °C pH: 5 Plating duration: 60 minutes

3.2. Surface morphology and microstructure

The percentage weight composition of the elements in the coatings is provided in Table 2 which indicates the presence of boron and nitrogen along with nickel and phosphorous.

Table 2. Elemental composition of the coating

Tabela 2. Elementarni sastav prevlake

Element	Atomic weight(%)
Boron	20.90
Nitrogen	12.17
Oxygen	18.69
Phosphorous	8.27
Nickel	39.97

Surface morphology of the coatings with and without c-BN at different plating time intervals is shown in Figure 2. Ni-P plating without c-BN was found to have spherical structure. With the incorporation of nano c-BN the coating was found to have uniform distribution with needle like structure. Few nodular lumps were seen at higher plating time.

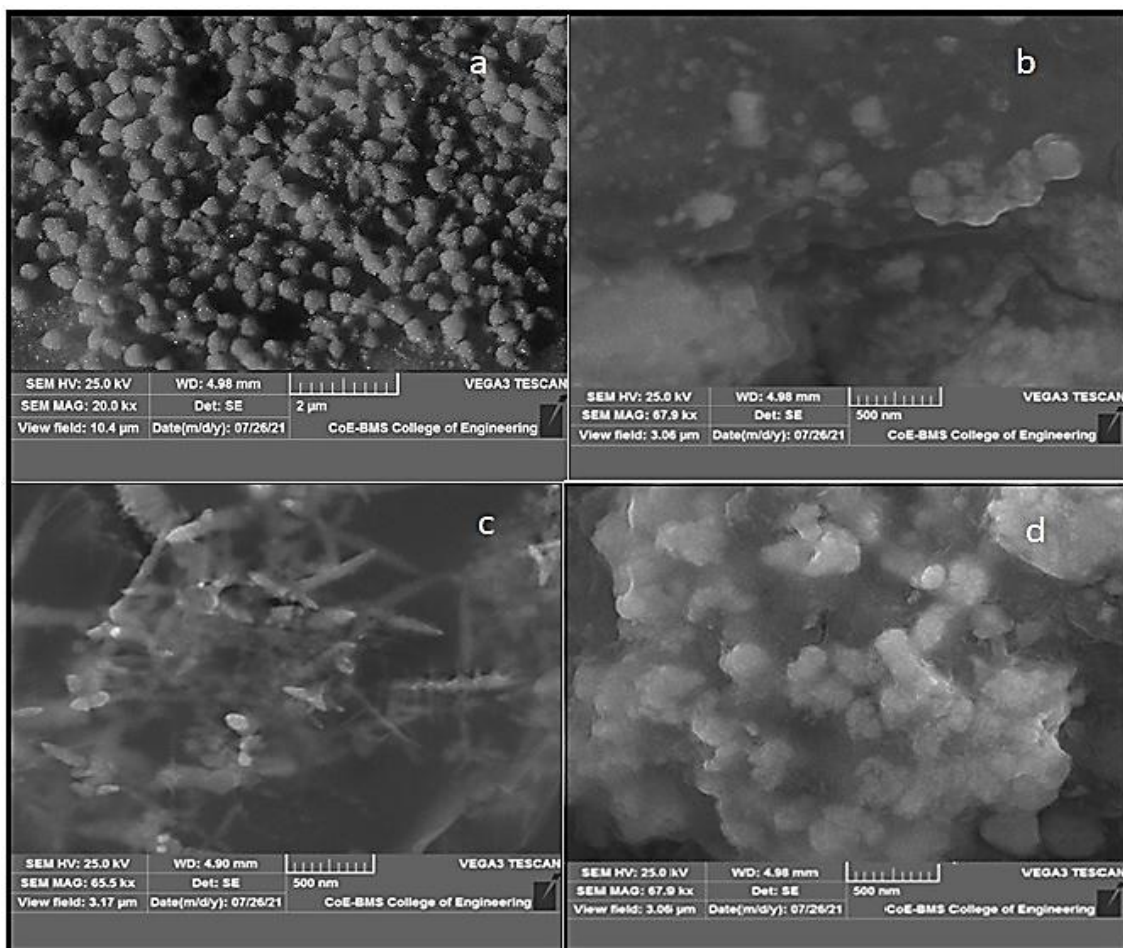

Figure 2. Microstructure of the deposits: a) Ni-P b) Ni-P/nano c-BN at 30 minutes of plating time c) Ni-P/nano c-BN at 1 hour of plating time d) Ni-P/nano c-BN at 2 hours of plating time

Slika 2. Mikrostruktura naslaga: a) Ni-P b) Ni-P/nano c-BN na 30 minuta nanošenja c) Ni-P/nano c-BN na 1 sat vremena nanošenja d) Ni-P/nano c-BN na 2 sata nanošenja

The XRD pattern of the nano c-BN reinforced electroless coating is presented in Figure 3 and it exhibit five distinct peaks. The diffraction pattern indicates the crystalline nature of the coatings. The maximum peak (111) corresponds to FCC structured crystalline nickel. In addition to nickel (111) peak, well defined peaks of Ni_3P (110) and BN (220) was observed. Other small peaks (311) and (211) corresponds to nickel and phosphorous. The studies also indicate that the nano c-BN is embedded well into the matrix of Ni-P. The average crystallite size of the ball milled nano c-BN was also calculated from the Debye-Scherrer formula [24] with the help of FWHM values of the peaks in the XRD pattern as epr our earlier publication [44]. The average crystallite size observed was 76nm.

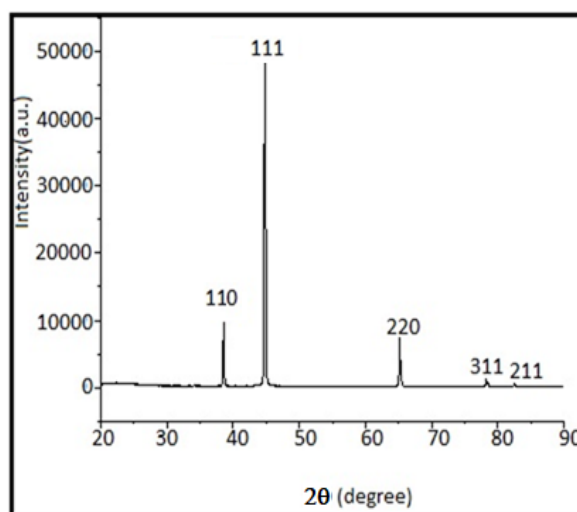

Figure 3. XRD pattern for Ni-P/nano c-BN plating
Slika 3. XRD uzorak za Ni-P/nano c-BN prevlaku

3.3. Electrochemical investigations

Electroless Ni-P/ nano c-BN composite coatings obtained from optimised plating bath (Table 1) were subjected to electrochemical corrosion measurements. The measurements were carried out for multiple samples and the concordant results obtained is reported.

3.3.1. Potentiodynamic polarization studies

Potentiodynamic polarisation experiments were carried out for electroless Ni-P/ nano c-BN composite coatings to investigate the corrosion behaviour of the coatings in both alkaline and acidic environments. The results were compared with bare aluminium and electroless Ni-P coatings. Figure 4a and 4b depicts the tafel plots of the samples measured in sodium hydroxide and hydrochloric acid medium respectively. It is evident that the composite coatings exhibit better protection irrespective of the type of medium compared to binary coatings. The corrosion current (I_{corr}) was calculated by using the equation given below. Polarization resistance was obtained from the Tafel slopes. The corrosion data is tabulated in Table 3.

$$b = \frac{\beta_a \beta_c}{(\beta_a + \beta_c) 2.303} \tag{1}$$

$$I_{corr} = b/R_p \tag{2}$$

where

b is Stern-Geary coefficient and R_p is polarization resistance

The nano c-BN reinforced coatings possess lower corrosion current values and offer high efficiency compared to bare Al 6061 and electroless Ni-P coatings. Higher electrochemical resistance of c-BN nano particles might be the reason for improved protection ability of the coatings [45]. Incorporation of nano c-BN has significant impact on the corrosion resistance of the composite coatings compared to that reported for other composite coatings with zirconium boron nitride, SiC and h-BN [46-49].

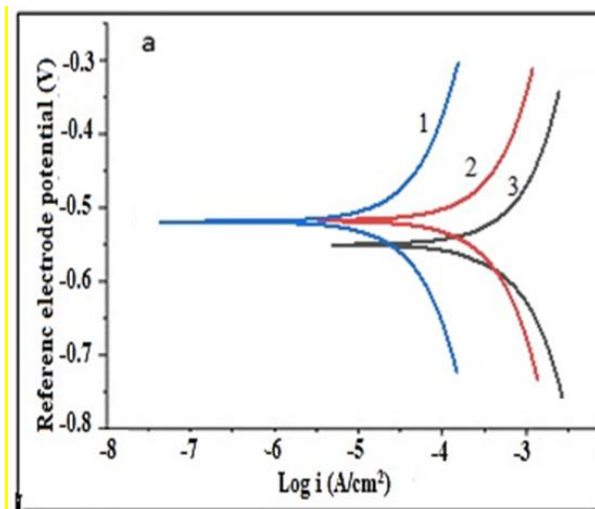

Figure 4 a. Current-Potential diagrams in 0.5N NaOH (1. Ni-P/nano c-BN 2. Electroless Ni-P 3. Al alloy)

Slika 4 a. Dijagrami strujnog potencijala u 0,5N NaOH (1. Ni-P/nano c-BN 2. Bezelektrični Ni-P 3. Al legura)

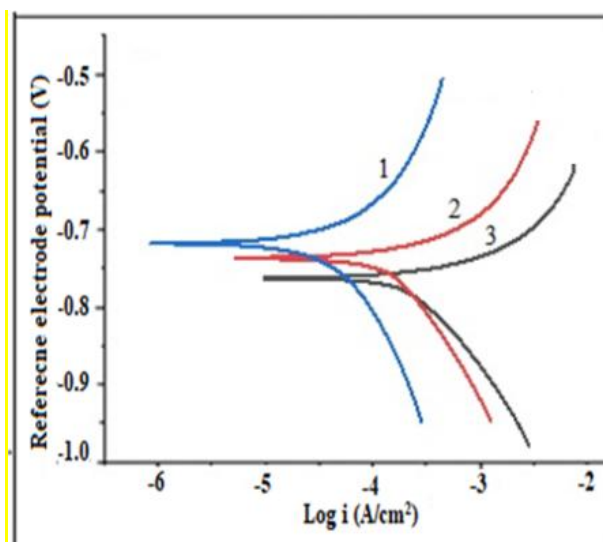

Figure 4 b. Current-Potential diagrams in 0.5N HCl (1. Ni-P/nano c-BN 2. Electroless Ni-P 3. Al alloy)

Slika 4 b. Dijagrami struja-potencijal u 0,5N HCl (1. Ni-P/nano c-BN 2. Bezelektrični Ni-P 3. Al legura)

Table 3. Polarization data of the samples in 0.5N NaOH and 0.5N HCl solution

Tabela 3. Podaci o polarizaciji uzoraka u 0.5N rastvoru NaOH i 0.5N HCl

Type of coating	Aluminium alloy		Ni/P		Ni-P/nano c-BN	
	NaOH	HCl	NaOH	HCl	NaOH	HCl
E_{corr} (V vs SCE)	-0.57	-0.79	-0.53	-0.75	-0.51	-0.71
β_a (V/dec)	0.068	0.075	0.292	0.395	0.316	0.422
β_c (V/dec)	-0.42	-0.69	-0.36	-0.61	-0.32	-0.52
I_{corr} ($\mu A/cm^2$)	18.2	22.6	9.8	14.3	4.3	6.8
PE (%)	-	-	79.8	71.8	94.8	86.2

3.3.2. Impedance studies

Nyquist plots obtained in corrosive media is presented in Figure 5a and 5b respectively for alkaline and acidic medium. Increase in the semicircle diameter of the specimen indicates higher impedance values as observed in case of composite coating [50].

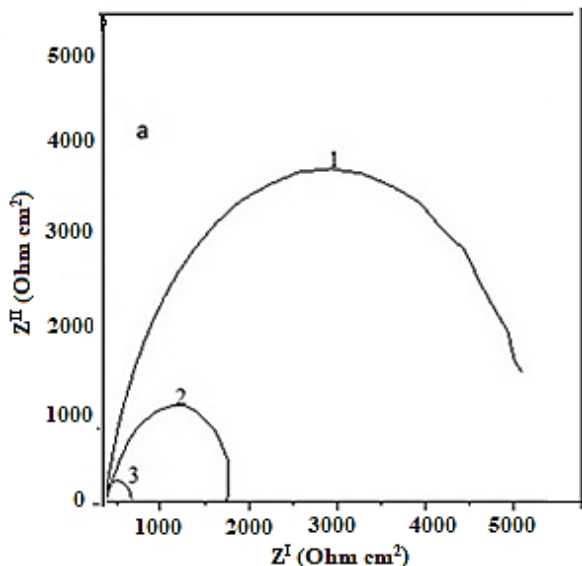

Figure 5a. Nyquist diagrams in 0.5N NaOH (1. Ni-P/nano c-BN, 2. Ni/P, 3. Aluminium alloy)

Slika 5a. Nyquist-ovi dijagrami u 0.5N NaOH (1. Ni-P/nano c-BN, 2. Ni/P, 3. legura aluminijuma)

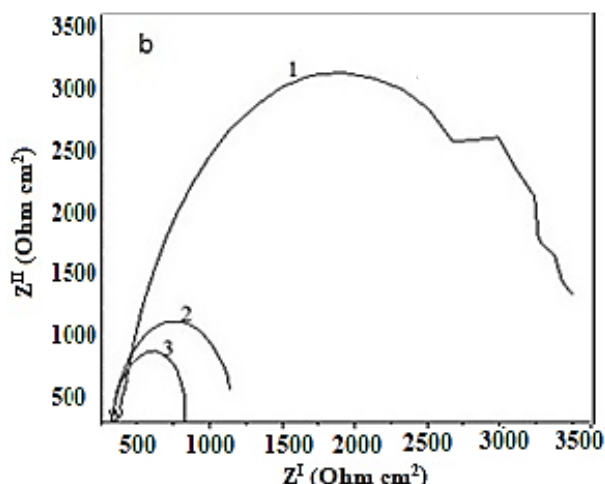

Figure 5b. Nyquist diagrams in 0.5N HCl (1. Ni-P/nano c-BN, 2. Ni/P, 3. Aluminium alloy)

Slika 5b. Nyquist-ovi dijagrami u 0.5N HCl (1. Ni-P/nano c-BN, 2. Ni/P, 3. legura aluminijuma)

The Bode plots of bare aluminium alloy, binary Ni-P as well as Ni-P/nano c-BN in acidic and alkaline media is provided in Figure 6 and 7. The higher impedance values were observed in case of composite coatings which confirms the higher corrosion resistance of the coatings. The minute voids in the Ni-P coatings is occupied by the nano c-BN particles leading to the improved resistance of the composite coatings [51]. The protection efficiency of nano composite coatings is less in acidic medium compared to that in alkaline medium. The Randel equivalent circuit for the above system is presented in Figure 8.

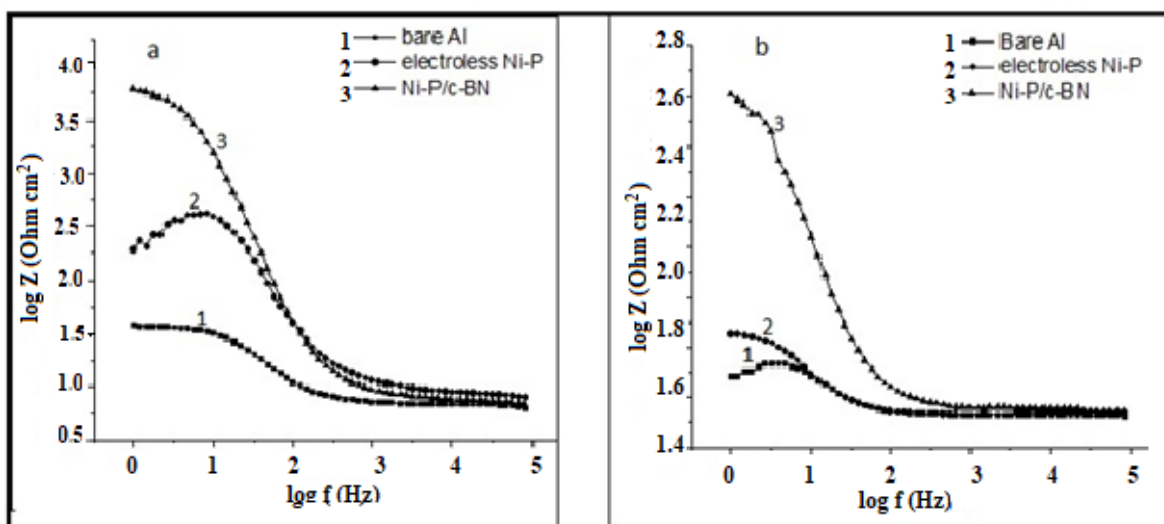

Figure 6. Bode amplitude plots of 1. Aluminium alloy 2. Ni/P 3. Ni-P/nano c-BN (a. 0.5N NaOH and b. 0.5N HCl)

Slika 6. Bode-ovi grafikoni amplitude 1. Legura aluminijuma 2. Ni/P 3. Ni-P/nano c-BN (a. 0.5N NaOH i b. 0.5N HCl)

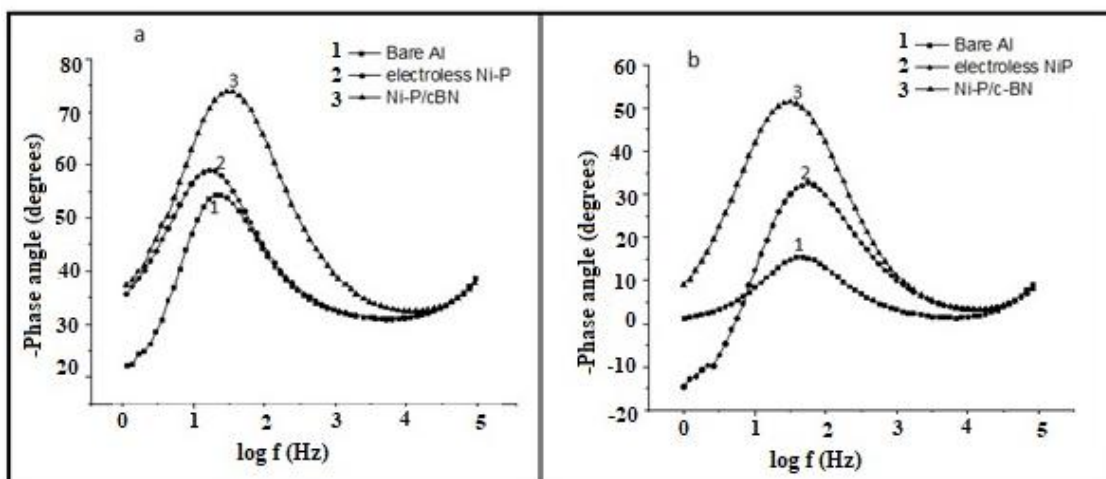

Figure 7. Bode Phase angle diagrams of 1. Aluminium alloy 2. Ni/P 3. Ni-P/nano c-BN (a. 0.5N NaOH and b. 0.5N HCl)

Slika 7. Bode-ovi dijagrami faznog ugla 1. Legura aluminijuma 2. Ni/P 3. Ni-P/nano c-BN (a. 0.5N NaOH i b. 0.5N HCl)

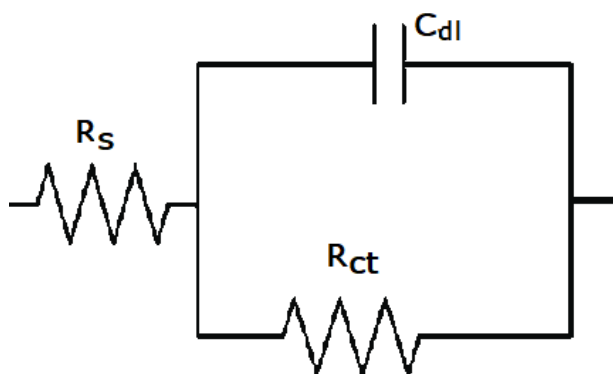

Figure 8. Randel circuit for the system

Slika 8. Rendel-ovo kolo za sistem

3.3.3. Neutral salt spray test

Salt spray tests were conducted by spraying 5% sodium chloride solution on the substrates for four days continuously. The specimens were observed for degradation under 4X magnification lens after every 2 hours by taking the specimens out of the fog chamber. After four days, the samples were removed, washed and dried in air [25]. The composite coating was stable up to 92 hours while the binary Ni-P coating started to degrade after 3days. The observation is in agreement with the electrochemical studies. Pin holes and grey spots were observed in both the samples after 4 days of exposure to fog.

3.4. Microhardness

Micro hardness of the electroless Ni-P plated specimens with and without nano c-BN, before and after heat treatment at 250°C for 2 hours was

determined by Vickers hardness method with 50 g load. The test was repeated for multiple samples and average microhardness recorded is tabulated in Table 4. Higher microhardness of composite coating may be attributed to the presence of hard nano c-BN in the coating. A remarkable increase in microhardness was observed after heat treatment owing to precipitation of the intermetallic Ni₃P in the coatings at high temperatures [51-52].

Table 4. Microhardness of the samples before and after heat treatment

Tabela 4. Mikrotvrdoća uzoraka pre i posle termičke obrade

Microhardness (VHN)→ ↓Type of coating	Before heat treatment	After heat treatment
Electroless Ni-P	96	101
Electroless Ni-P/nano c-BN	185	202

3.5. Testing evaluation

All the samples were inspected visually for defects under 4X magnification lens. Deposits were found to be uniform and even over the entire surface of the substrate.

3.5.1. Adhesion test

The adherence strength of the composite coating to the substrate was investigated by scotch tape peel off method. In this test 100 squares of 4 mm² were scribed through the coatings. A pressure sensitive tape of one- inch was then applied tightly

over the coating by rolling a roller covered with rubber over the tape twice. The pressure sensitive tape was taken off at right angle to the coating. The samples were later inspected visually for any detachment in the coating. The coating was found to adhere to the surface firmly.

3.5.2. Heat treatment

The binary Ni-P and nano c-BN reinforced composite coatings were heat treated in a hot air oven at 250°C for 6 hours to study the effect of high temperature on the physical nature of the coating and hardness. After 6 hours the test samples were taken out of the oven and inspected for any physical changes. No degradation like discolouration, blisters or pits were observed.

3.5.3. Humidity test

Humidity test is conducted to study the effect of relative humidity and high temperature on the samples, which in turns related to corrosion protection efficiency [53]. This test is conducted by placing the samples in a thermostatically controlled humidity chamber for two days under $95 \pm 5\%$ relative humidity at 50°C. After 48 hours, the specimens were removed from the chamber and observed for any defects or degradation under 4X lens. Blisters and discoloration was observed on electroless Ni-P coatings and no degradation was observed in case of Ni-P/nano c-BN coatings indicating higher stability under humid conditions.

4 CONCLUSIONS

The Ni-P/nano c-BN composite coatings were obtained by eco-friendly electroless method. EDX and XRD studies confirms the presence of nickel, phosphorous, boron and nitrogen in the composite coatings. Needle like structure with few agglomerates were observed in scanning electron micrographs. Electroless Ni-P/nano c-BN coatings exhibited better protection against corrosion in both acidic and alkaline media as indicated by polarization, impedance and salt spray studies. Incorporation of nano c-BN enhanced the barrier properties of the coatings providing higher protection indicating these coatings can be used for corrosion protection applications both in acidic and alkaline environments. Nano c-BN reinforced coatings exhibited improved hardness compared to electroless Ni-P coatings. The improved hardness is attributed to the incorporation of hard nano c-BN in the coatings. The micro hardness of the composite coatings increased after heat treatment due to precipitation of Ni_3P . The composite coatings exhibited excellent stability to higher temperatures and humid environment.

5. REFERENCES

- [1] L.Ramesh et al. (1999) Electrolytic preparation and characterization of Ni-Fe-Mo alloys: Cathode materials for alkaline water electrolysis, *Int. J. Energy Res.*, 23(10), 919-924, [https://doi.org/10.1002/\(SICI\)1099-114X\(199908\)23:10%3C919::AID-ER524%3E3.0.CO;2-D](https://doi.org/10.1002/(SICI)1099-114X(199908)23:10%3C919::AID-ER524%3E3.0.CO;2-D)
- [2] G.O.Mallory et al. (1990) *Electroless plating: Fundamentals and Applications*, AESF, Orlando, FL., 207(a), 189 (b).
- [3] Chintada et al. (2021) State of Art Review on Nickel-Based Electroless Coatings and Materials, *J. Bio. Tribo.*, 7, 134, 3-14, <https://doi.org/10.1007/s40735-021-00568-7>.
- [4] M.Yan et al. (2008) Improved microhardness and wear resistance of the as-deposited electroless Ni-P coating, *Surf. Coat. Technol.*, 20(24), 5909-5913, <https://doi.org/10.1016/j.surfcoat.2008.06.180>.
- [5] T. Mimani et al. (1996) The effect of microstructure on the corrosion behaviour of electroless Ni-P alloys in acidic media, *Surf. Coat. Technol.*, 79 (1), 246-251, [https://doi.org/10.1016/0257-8972\(95\)02446-8](https://doi.org/10.1016/0257-8972(95)02446-8)
- [6] J. Flis et al. (1985) Effect of phosphorous on Anodic Dissolution and passivation on Nickel in near-neutral solution, *Corrosion*, 41, 700-706, <https://doi.org/10.5006/1.3583006>.
- [7] K.Sugita et al. (1984) Composition and Crystallinity of Electroless Nickel, *J. Electrochem. Soc.*, 131(1), 111-114, <https://doi.org/10.1149/1.2115488>.
- [8] P. Murukesan et al. (2007) Hardness and structural correlation for electroless Ni alloy deposits, *J. Mater. Sci.*, 42, 6600-6607, <https://doi.org/10.1007/s10853-007-1501-5>.
- [9] M. Meng et al. (2019) Mechanical properties and tribological behaviour of electroless Ni-P-Cu coatings on corrosion-resistant alloys under ultrahigh contact stress with sprayed nanoparticles, *Tribology International*, 139, 59-66, <https://doi.org/10.1016/j.triboint.2019.06.031>.
- [10] C.J. Chen et al. (1999) A Mathematical Model of an Electrochemical Capacitor with Double-Layer and Faradaic Processes, *J. Electrochem Soc.*, 146(9), 3168-3175, <https://doi.org/10.1149/1.1392450>.
- [11] Fan-Bean Wu et al. (2007) Fabrication and characterization of the Ni-P-Al-W multicomponent coatings, *Surf. Coat. Technol.*, 202, 762-767, <https://doi.org/10.1016/j.surfcoat.2007.06.070>.
- [12] Shu et al. (2015) Parameter optimization for Electroless Ni-P-W coatings, *Surf. Coat. Technol.*, 276, 195-201, <https://doi.org/10.1016/j.surfcoat.2015.06.068>.
- [13] M.S.Ali Eltoun (2016) Electroless and corrosion of Nickel-Phosphorus-Tungsten Alloy, *The J of Middle East and North Africa Sciences*, 2(2), 16-24, <https://doi.org/10.12816/0032658>.
- [14] C.F.Conde et al. (1989) Non-isothermal crystallization and isothermal transformation kinetics of the Ni-Cr-P metallic glass, *J. Mater. Sci.*, 24, 139-142, <https://doi.org/10.1007/BF00660945>.

- [15] A.R.Shashikala et al. (2007) Studies and characterisation of electroless Ni–Cr–P alloy coatings, *Trans. IM.*, 85(6), 320-325, <https://doi.org/10.1179/174591907X246483>.
- [16] K Parker (1996) The Effect of Nickel Salts on Electroless Nickel Plating, *Plat. Surf. Finish.*, 83(1), 70-71, 70, 71 (nmfrc.org).
- [17] Wei-Yu Chen et al. (2004) Thermal stability of sputtered Ni–P and Ni–P–Cr coatings during cycling test and annealing treatment, *Surf. Coat. Technol.*, 177–178 (6), 222-226, <https://doi.org/10.1016/j.surfcoat.2003.09.036>.
- [18] G.G. Gawrilov (1979) Chemical electroless nickel plating, Portullis press, Redhill, p.168.
- [19] S.Singh Siwal et al. (2023) A review on electrochemical techniques for metal recovery from waste resources, *Current Opinion in Green and Sustainable Chemistry*, 39, 100722, <https://doi.org/10.1016/j.cogsc.2022.100722>.
- [20] Sh. Liu et al. (2021) Mechanistic study of Ni–Cr–P alloy electrodeposition and characterization of deposits, *Journal of Electroanalytical Chemistry*, 897, 115582, <https://doi.org/10.1016/j.jelechem.2021.115582>.
- [21] C.R.Shipley (1984) Historical highlights of electroless plating, *Plating and Surface Finishing*, 71(6), 24-27.
- [22] S.Karthikeyan et al. (2014) Effect of reducing agent and nano Al₂O₃ particles on the properties of electroless Ni-P coating, *Appl Surf Sci.*, 307, 654-660, <https://doi.org/10.1016/j.apsusc.2014.04.092>.
- [23] S. Sadreddini et al. (2014) Corrosion resistance enhancement of Ni-P-nano SiO₂ Composite coatings on Aluminium, *Appl Surf sci.*, 303, 125-130. <https://doi.org/10.1016/j.apsusc.2014.02.109>.
- [24] Y.Y.Liu et al. (2007) Synthesis and tribological behavior of electroless Ni-P-WC nano composite coatings, *Surf Coat Tech.*, 201(16-17), 7246-7251, <https://doi.org/10.1016/j.surfcoat.2007.01.035>.
- [25] A.R.Shashikala et al. (2021) Co-deposition of electroless Ni-P-ZnO composites and evaluation of corrosion resistance of the coatings, *Mater. Today proceed.*, 45, 3837-3840, <http://doi.org/10.1016/j.matpr.2020.05.447>.
- [26] Kh.Shahzad et al. (2020) Corrosion &Heat treatment study of electroless Ni-P-Ti nanocomposite coatings deposited on HSLA steel, *Nanomaterials.*, 10, 1-19, <https://doi.org/10.3390/nano10101932>.
- [27] A.V.Sreenu (2018) Aluminium-Boron Nitride nano composite coating by friction surfacing on low carbon steel substrate-a feasibility study, *Mater. today proceed.*, 5, 26829-26835, <https://doi.org/10.1016/j.matpr.2018.08.164>.
- [28] Ch. Zhao et al. (2014) Preparation and mechanical properties of electroless Ni–P–WC nano composite coatings, *JMEP*, 23, 193-197, <http://doi.org/10.1007/s11665-013-0753-2>.
- [29] He.-Zhi Zhou et al. (2016) Preparation research of Nano-SiC/Ni-P composite coating under a compound field, *IOP Conf. Series: Materials Science and Engineering* 137, 012066, <http://doi.org/10.1088/1757-899X/137/1/012066>.
- [30] S.R.All. Karam et al. (2012) An Investigation on Effects of TiO₂ Nano-Particles Incorporated in Electroless NiP Coatings Properties, *International J. Modern physics conference series.*, 05, 833-840, <https://doi.org/10.1142/S2010194512002814>.
- [31] S.Sharma et al. (2016) Co-deposition of Synthesized ZnO Nanoparticles into Ni-P Matrix Using Electroless Technique and Their Corrosion Study, *JMEP.*, 25, 4383-4393, <http://doi.org/10.1007/s11665-016-2292-0>.
- [32] H. Luo et al. (2015) Development of electroless Ni-P/nano WC composite coatings and investigation on its properties, *Surf Coat Tech*, 277, 99-106, <https://doi.org/10.1016/j.surfcoat.2015.07.011>.
- [33] K.A.Bello et al. (2015) Synthesis and characterization of Ni-P coated Hexagonal Boron Nitride by electroless Nickel Deposition, *Surf Engg & appl Electrochem.*, 51 (6), 523-529, <https://doi.org/10.3103/S1068375515060058>.
- [34] Zh. Shitang et al. (2008) Friction and Wear Behavior of Laser Cladding NiAl/hBN Self-Lubricating Composite Coating, *Mater. Sci Eng., A* 491 (1), 47-54, <http://doi.org/10.1016/j.msea.2007.12.015>.
- [35] Bi.-Cuong et al. (2019) Operational and environmental conditions regulate the frictional behavior of two-dimensional materials, *Appl Surf Sci.*, 483, 34-44, <https://doi.org/10.1016/j.apsusc.2019.03.249>.
- [36] S Kumari et al. (2019) Electrochemical behavior of nanostructured graphene nickel phosphorus composite coating on copper, *J Appl Electrochem.*, 49, 1157-1166, <https://doi.org/10.1007/s10800-019-01333-y>.
- [37] P.P.Krishnamoorthy et al. (1992) Properties of electroless nickel-phosphorus deposits after crystallization, *Metal Finishing.*, 90, 13-17.
- [38] A.Talat El-Mallah et al. (1993) Autocatalytic (Electroless) deposition of nickel-phosphorus-boron alloys - Part III, *Metal Finishing.*, 91, 19-21.
- [39] D.Baudrand (1996) Nickel sulfamate plating, its mystique and practicality, *Metal Finishing.*, 94 (7), 15-18, [https://doi.org/10.1016/0026-0576\(96\)81353-5](https://doi.org/10.1016/0026-0576(96)81353-5)
- [40] W.Sha et al. (2011) Crystallisation of nickel–phosphorus (Ni–P) deposits with medium and low phosphorus content”, Editor(s): W. Sha, X. Wu, K.G. Keong, In *Woodhead Publishing Series in Metals and Surface Engineering, Electroless Copper and Nickel–Phosphorus Plating*”, Woodhead Publishing, 163, <http://doi.org/10.1533/9780857090966.2.163>.
- [41] K.Parker (1987) The Formulation of Electroless Nickel-Phosphorus Plating Bath, *Plating and Surface Finishing*, 74(2), 60-65, <https://api.semanticscholar.org/CorpusID:102381908>
- [42] A.R.Shashikala et al. (2006) Studies on solar selective black chrome plating on Al alloys, *Galvanotechnik.*, 10, 1-14.
- [43] C.R.Raghavendra (2016) Electrodeposition of Ni-Al₂O₃ nano composite coating and evaluation of wear characteristics, *IOP Conf. Ser.: Mater. Sci.*

- Eng, 149, 012110, <http://doi.org/10.1088/1757-899X/149/1/012110>.
- [44] A.R.Shashikala et al. (2023) The effect of ball milling on the morphology of cubic boron nitride, Malaysian Journal of Science, 42 (3), 19-25, <https://doi.org/10.22452/mjs.vol42no3.4>.
- [45] M.Alishahi et al. (2012) The effect of carbon nanotubes on the corrosion and tribological behavior of electroless Ni-P-CNT composite coating, Appl Surf Sci., 258, 2439-2446, <https://doi.org/10.1016/j.apsusc.2011.10.067>.
- [46] M.Urgen et al. (1995) Corrosion of zirconium boride and zirconium boron nitride coated steels, Surf. Coat. Tech., 71(1), 60-66, [https://doi.org/10.1016/0257-8972\(94\)02316-1](https://doi.org/10.1016/0257-8972(94)02316-1).
- [47] A.Kumar et al. (2022) Sputter-grown hierarchical nitride (TiN & h-BN) coatings on BN nanoplates reinforced Al7079 alloy with improved corrosion resistance, Surf. Coat. Tech., 432, 128-161, <https://doi.org/10.1016/j.surfcoat.2021.128061>.
- [48] Y.Fan et al. (2020) Corrosion Resistance of Modified Hexagonal Boron Nitride (h-BN) Nanosheets Doped Acrylic Acid Coating on Hot-Dip Galvanized Steel, Materials, 13 (10), 2340-2350, <https://doi.org/10.3390/ma13102340>.
- [49] X.Fu et al. (2020) Corrosion resistance of Ni-P/SiC and Ni-P composite coatings prepared by magnetic field-enhanced jet electrodeposition, RSC Adv., 10(56), 34167-34176, <https://doi.org/10.1039/D0RA06735K>.
- [50] A.R.Shashikala et al. (2008) Chemical conversion coatings on Magnesium Alloys-A comparative study, Int. J. Electrochem. Sci., 3(9), 993-1004, [https://doi.org/10.1016/S1452-3981\(23\)15498-8](https://doi.org/10.1016/S1452-3981(23)15498-8).
- [51] B.Radwan, K.Ali et al. (2018) Properties enhancement of Ni-P electrodeposited coatings by the incorporation of nanoscale Y2O3 particles, Appl. Surf. Sci., 457, 956-967, <https://doi.org/10.1016/j.apsusc.2018.06.241>.
- [52] I.Apachitei et al. (1998) Electroless Ni-P Composite Coatings: The Effect of Heat Treatment on the Microhardness of Substrate and Coating, Scripta Materialia, 38(9), 1347-1353, [https://doi.org/10.1016/S1359-6462\(98\)00054-2](https://doi.org/10.1016/S1359-6462(98)00054-2).
- [53] W.Ya Li et al. (2011) Effect of vacuum heat treatment on microstructure and microhardness of cold-sprayed TiN particle-reinforced Al alloy-based composites, Mater & Design., 32(1), 388-394, <https://doi.org/10.1016/j.matdes.2010.06.002>.

IZVOD

ELEKTROHEMIJSKA ISPITIVANJA Ni-P/NANO c-BN NANESENIH NA LEGURU ALUMINIJUMA

Elektrohemijska ispitivanja su obavljena na prevlakama Ni-P/nano kubni bor nitridom (c-BN) dobijenim korišćenjem rastvora u kupatilu elektrolita redukovanog natrijum hipofosfitom sa agensima za stvaranje kompleksa. Skrining agenasa za stvaranje kompleksa je sproveden UV-Visible spektrofotometrijskim studijama. Naslage dobijene korišćenjem optimizovanog sastava kupatila su testirane pomoću EDAX, SEM i XRD da bi se razumela strukturna morfologija premaza. Elektrohemijske studije sprovedene pomoću potenciodinamičke polarizacije i elektrohemijske impedansne spektroskopije (EIS) otkrile su veću stabilnost premaza u kiseloj i alkalnoj sredini. Da bi se procenilo ponašanje premaza u morskom okruženju, sprovedeno je ispitivanje slanim sprejom korišćenjem rastvora natrijum hlorida. Rezultati ukazuju na poboljšanu otpornost na koroziju ugradnjom nano c-BN u prevlake.

Ključne reči: kubni-bor nitrid, otpornost na koroziju, polarizacija, EIS, slani sprej

Naučni rad

Rad primljen: 25.09.2023.

Rad korigovan: 29.11.2023.

Rad prihvaćen: 07.12.2023.

Rad je dostupan na sajtu: www.idk.org.rs/casopis